

GRAVELY

LT TRACTOR

ILLUSTRATED PARTS LIST EFFECTIVE DATE

JUNE 1, 1965



To continue its program of quality and design improvement, the manufacturer reserves the right to change specifications, designs or prices without notice and without incurring obligation.

Tractors with manufacturing numbers
(See Name Plate) A-1 through I.--

GRAVELY



GRAVELY LANE
DUNBAR
WEST VIRGINIA 25064

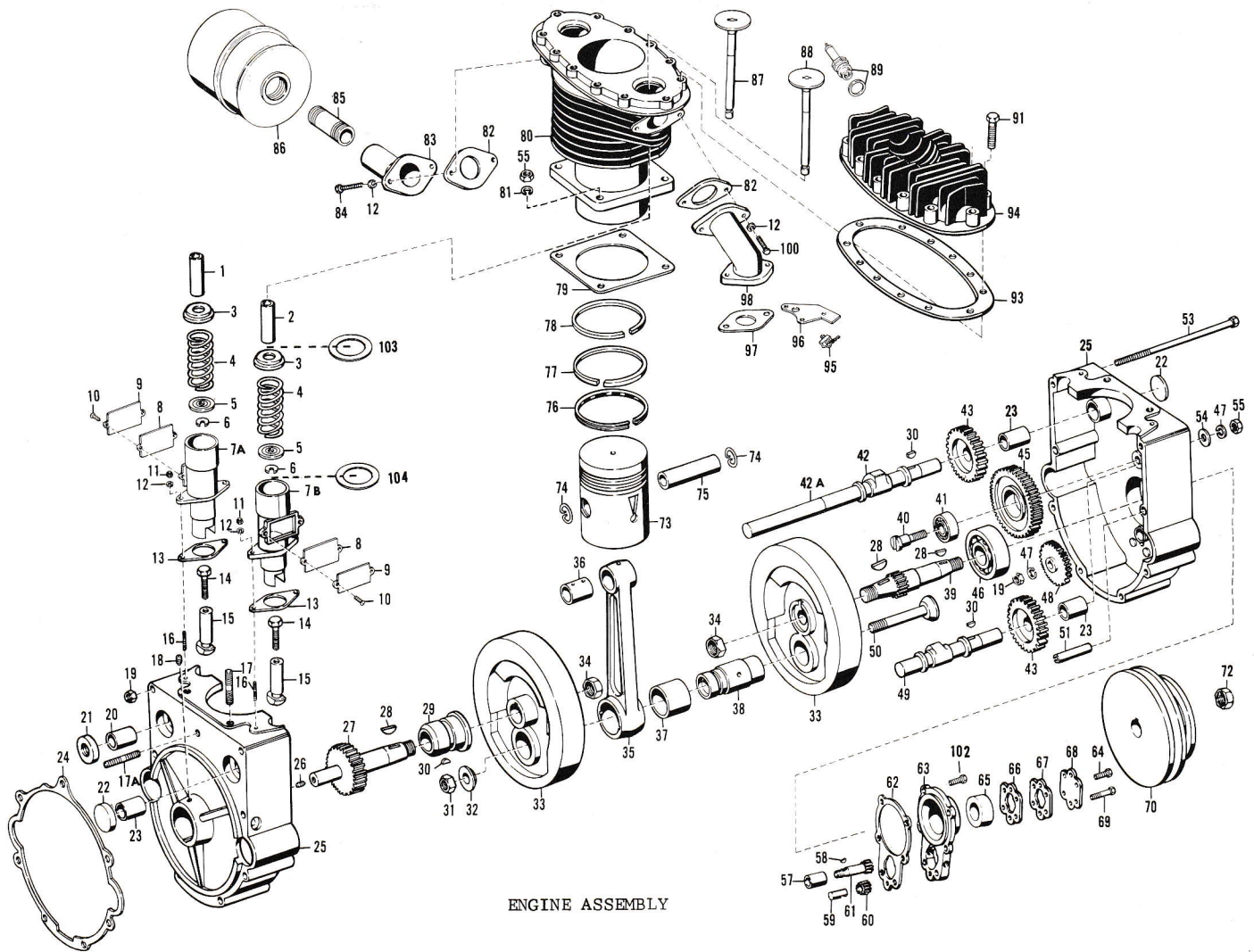

Item No.	Part No.	Description	Quan. Req'd.
1	L-881-X	Valve Guide Bronze	1
2	L-881-N	Valve Guide, Cast Iron	1
3	L-882	Valve Spring Locator Sleeve	2
4	L-312	Valve Spring	2
5	5741	Valve Spring Cap	2
6	5742	Valve Spring Cap Key	2
7-A	L-403-A	Valve Spring Plunger Guide & Cover Ex.Side	1
7-B	L-403-B	Valve Spring Plunger Guide & Cover w/keyway	1
8	L-879	Valve Cover Gasket	2
9	L-878	Valve Cover Cap	2
10	101-S	Screw	4
11	202-N	Nut	4

ENGINE ASSEMBLY Con't.

Item No.	Part No.	Description	Quan. Req'd.
12	303-W	Lock Washer	8
13	L-407-A	Valve Plunger Gasket	2
14	L-880	Valve Tappet Screw	2
15	L-404	Valve Plunger	2
16	L-405	Plunger Guide Stud	4
17	L-304	Cylinder and Crankcase Stud	4
17-A	L-303	Crankcase to Chassis Stud	1
18	803-A	Set Screw	1
19	214-N	Nut	3
20	L-406-I	Camshaft Bushing	1
21	L-412	Camshaft Oil Seal	1
22	L-414	Expansion Plug	3
23	L-426	Cam Shaft Bushing	3
24	L-210	Gasket, Motor to Chassis	1
25	L-101-2	Crankcase Complete (Matched Set)	1
26	801-A	Set Screw	1
27	L-109	Drive Pinion Shaft	1
28	514-K	Woodruff Key	3
29	L-117	Drive Pinion Bearing	1
30	503-K	Woodruff Key	3
31	210-N	Nut	1
32	L-107	Spreader Bolt Washer	1
33	L-104	Flywheel	2
34	L-112	Flywheel Nut	2
35	L-863	Connecting Rod Complete with Bushing	1
36	L-306-A	Connecting Rod Bushing	1
37	L-306-B	Connecting Rod Bushing, Large	1
38	L-105	Crank Pin	1
39	L-110	Timing Pinion Shaft	1
40	L-417	Bearing Stud	1
41	L-416	Idler Gear Bearing	1
42	L-402	Exhaust Cam Shaft	1
42-A	L-810-A	Camshaft Extension	1
43	L-413	Camshaft Gear	2
45	L-415	Idler Gear	1
46	L-115	Timing Pinion Bearing	1
47	305-W	Lock Washer	2
48	L-419-A	Oil Pump Drive Gear	1
49	L-424	Intake Cam Shaft	1
50	L-106	Spreader Bolt	1
51	L-120	Crankcase Dowel	2
53	L-116	Crankcase Bolt	8
54	403-W	Flat Washer	1
55	206-N	Nut	5
57	L-420-B	Oil Pump Bushing	1
58	507-K	Woodruff Key	1
59	L-855	Idler Gear Pin	1
60	L-854	Idler Gear	1
61	L-853	Master Gear	1
62	L-125	Bearing Cap Gasket	1
63	L-850	Bearing and Pump Cap	1
64	165-S	Bolt	3
65	L-126-A	Oil Seal	1
66	L-852	Gasket	1

Item No.	Part No.	Description	Quan. Req'd.
67	L-852-A	Shim (.005) Gasket	(as req.)
68	L-851	Pump Cover	1
69	185-S	Bolt	3
70	5745	Fan Drive Pulley	1
72	218-N	Fan Drive Pulley Nut	1
73	LH-543	Piston with Pin	1
74	LH-545	Piston Pin Lock	2
75	LH-544	Piston Pin	1
76	LH-546-C	Oil Ring (3 pc.- 2 rings, 1 expander)	1
77	LH-547	Compression Ring	1
78	LH-548	Chromed Compression Ring	1
79	L-317	Cylinder Bottom Gasket	1
80	5733	Cylinder	1
81	306-W	Heavy Lock Washer	4
82	L-407-C	Manifold Gasket, Exhaust & Intake	2
83	L-301-D	Manifold, Exhaust	1
84	164-SG	Manifold Bolt, Graphited, Exhaust	2
85	8255	Nipple	1
86	8227	Muffler	1
87	L-311-X	Valve, Exhaust	1
88	L-311-N	Valve, Intake	1
89	1709	Spark Plug & Washer	1
91	154-S	Cylinder Head Bolt, Short	10
93	5735	Cylinder Head Gasket	1
94	5734	Cylinder Head	1
95	7331	Speed Clip	1
96	7176	Manual Choke Bracket	1
97	L-301-B	Gasket, Manifold to Carburetor	1
98	L-301-A	Manifold Intake	1
100	183-S	Manifold Bolt, Intake	2
102	183-S	Bolt	4
103 NS	L-874	Gasket, Locator to Cylinder	2
104 NS	L-876	Gasket, Valve Cover to Locator	2

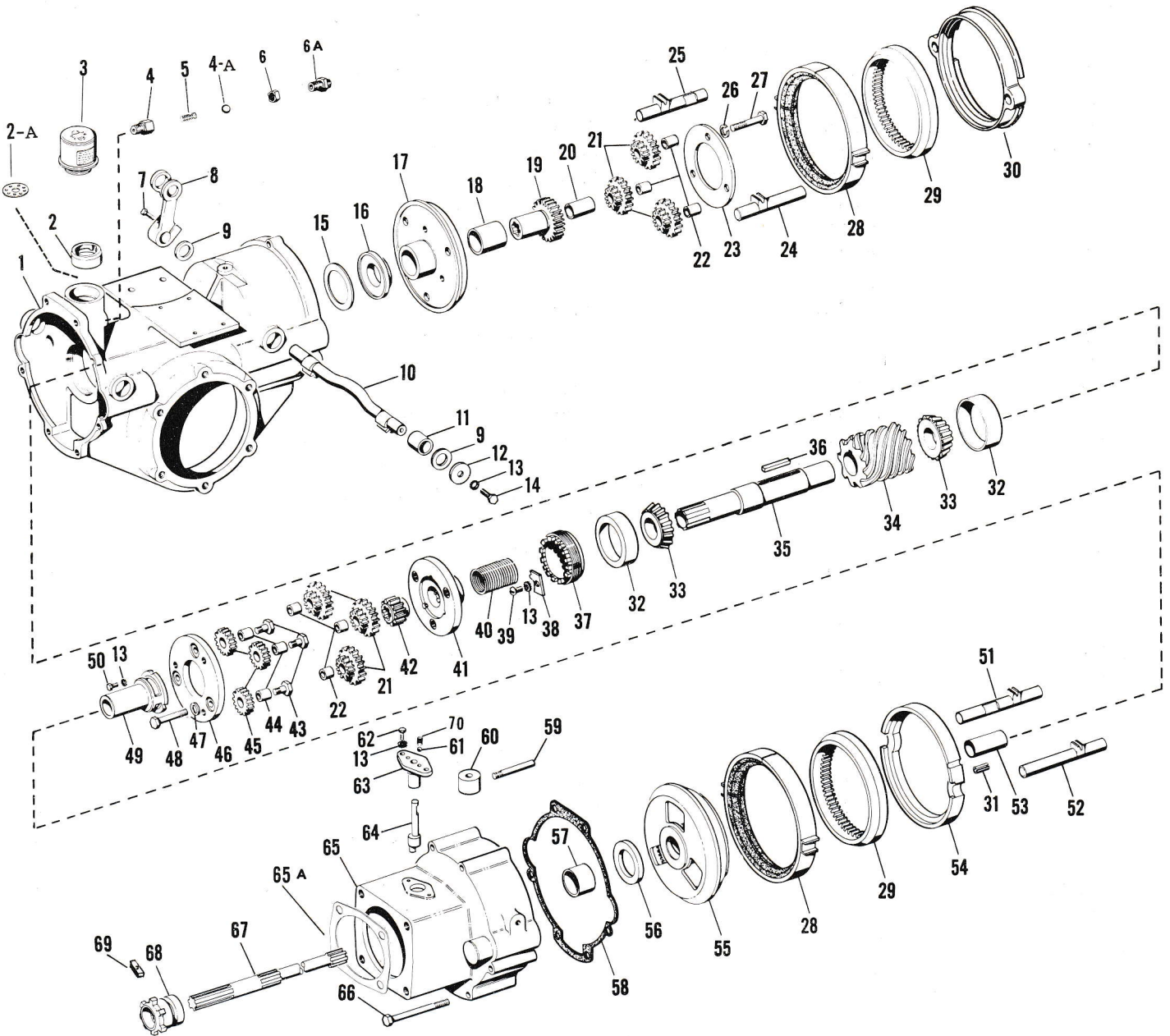

MODEL LT CHASSIS

Item No.	Part No.	Description	Quan. Req'd.
1	L-201	Chassis Casting	1
2	L-211	Chassis Oil Filler Neck	1
2-A	L-864	Filler Neck Baffle	1
3	L-212	Chassis Oil Filler Cap Breather	1
4	8231	Relief Valve Body	1
4-A	L-865	Relief Valve Check Ball	1
5	L-815-D	Spring .025"	2

CHASSIS Con't.

Item No.,	Part No.	Description	Quan. Req'd.
6	NJ-7-F	Nut Adjustable	
6-A	8230	Relief Valve	
7	154-S	Actuating Lever Clamp Bolt	2
8	L-715	Actuating Shaft Lever	2
9	L-735	Oil Seal Washer	1
10	L-712	Clutch Actuating Shaft	2
11	L-713	Actuating Shaft Bushing	4
12	L-736	Thrust Washer	2
13	303-W	Securing Bolt Washer	8
14	165-S	Bolt	2
15	2211	Rear Thrust Plate Shim (.020)	1
16	L-519	Rear Thrust Plate	1
17	L-506	Rear Pin Plate	1
18	L-535	Rear Pin Plate Bushing	1
19	L-511	Sun Gear	1
20	L-534	Sun Gear Bushing	1
21	L-513	Orbit Gear	6
22	L-514	Orbit Gear Pin	6
23	L-515	Pin Spacer	1
24	L-711-L	Clutch Slide Rod, Short	1
25	L-711-R	Clutch Slide Rod, Short	1
26	305-WL	Spacer Lock Washer Left Hand	3
27	L-516-L	Spacer Bolt Rear Pin Plate (L.H. Thread)	3
28	L-517	Clutch Cup	2
29	L-501	Internal Gear	2
30	L-524	Rear Spacer	1
31	HE-106	Roll Pin	1
32	L-522-R	Worm Shaft Bearing Race	2
33	L-522-C	Worm Shaft Bearing Cone	2
34	L-601	Worm, Standard, (Specify 4,6,or 8 lead)	1
35	L-521	Worm Shaft	1
36	L-608	Worm Key	1
37	L-507	Bearing Adjusting Nut	1
38	L-523	Adjusting Nut Lock	1
39	164-S	Lock Screw	1
40	L-547	Pin Plate Spacer Spring	1
41	L-505	Front Pin Plate	1
42	L-510	Sun Pinion	1
43	L-542	Reverse Idler Bolt	3
44	L-541	Reverse Idler Bushing	3
45	L-540	Reverse Idler	3
46	L-539	Front Pin Spacer	1
47	305-W	Spacer Lock Washer	3
48	L-516-R	Spacer Bolt Front Pin Plate	3
49	L-536	Pin Plate Quill	1
50	191-S	Quill Securing Bolt	3
51	L-710-R	Clutch Slide Rod, Long	1
52	L-710-L	Clutch Slide Rod, Long	1
53	L-546	Pinion Shaft Bearing	1
54	L-508	Gear Cup	1
55	L-538	Reverse Cone	1
56	L-520	Front Thrust Plate	1
57	L-532	Quill Bearing	1

CHASSIS Con't.

Item No.	Part No.	Description	Quan. Req'd.
58	L-209	Chassis Front Gasket	1
59	L-732	Shipper Shaft Lever	1
60	L-733	Locator Body	1
61	1809	Locator Ball	1
62	164-S	Shipper Shaft Guide Bolt	2
63	L-734	Shipper Shaft Guide	1
64	L-545	Shipper Shaft	1
65	L-202	Advance Casting	1
65-A	5056	Attachment Gasket	4
66	L-207	Advance Casting Bolt	6
67	L-543	Pinion Shaft	1
68	L-544	Clutch Dog	1
69	L-226	Dog Plate	1
70	L-132	Spring	1
NS	152-S	Attachment Bolt	4

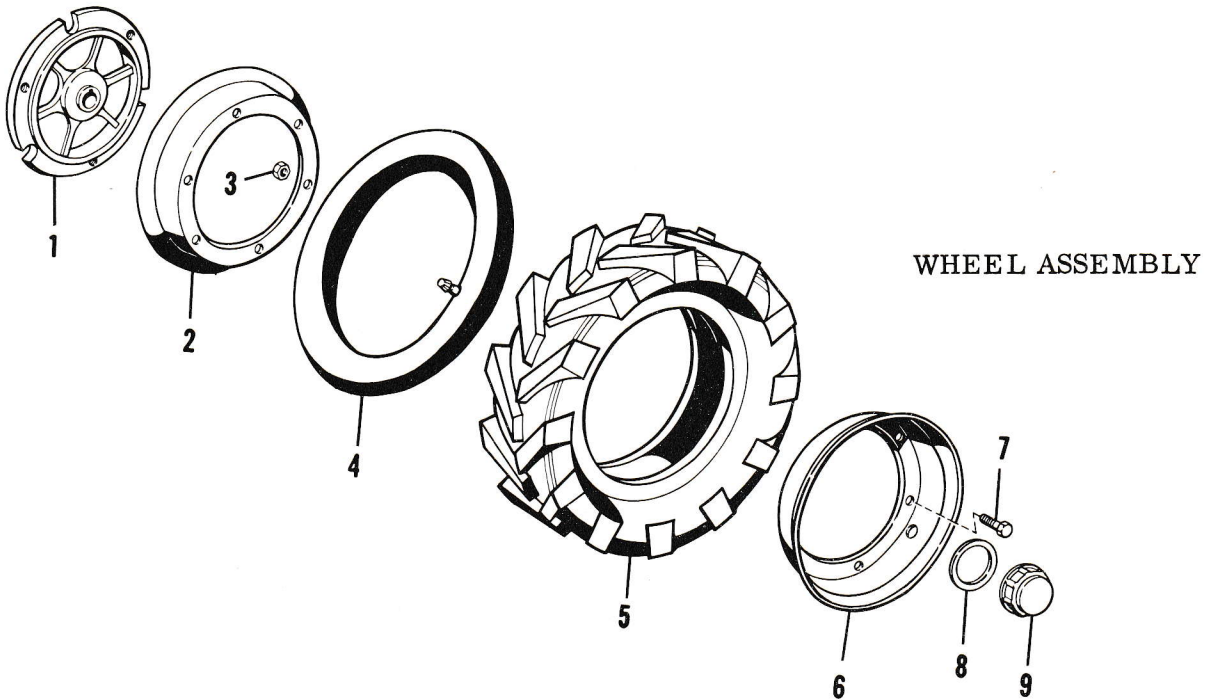

Item No.	Part No.	Description	Quan. Req'd.
1	L-614-B	Wheel Hub	2
2	L-616-IR	Inner Rim	2
3	3509	Rim Bolt Nuts	6
4	L-616-TU	Tractor Tire Tube	2
5	L-616-TI	Tractor Tire, sure grip or studded	2
6	L-616-OR	Outer Rim, (with valve hole)	2
7	179-S	Rim Bolts	6
8	L-613	Hub Cap Washer	2
9	L-619	Hub Cap	2

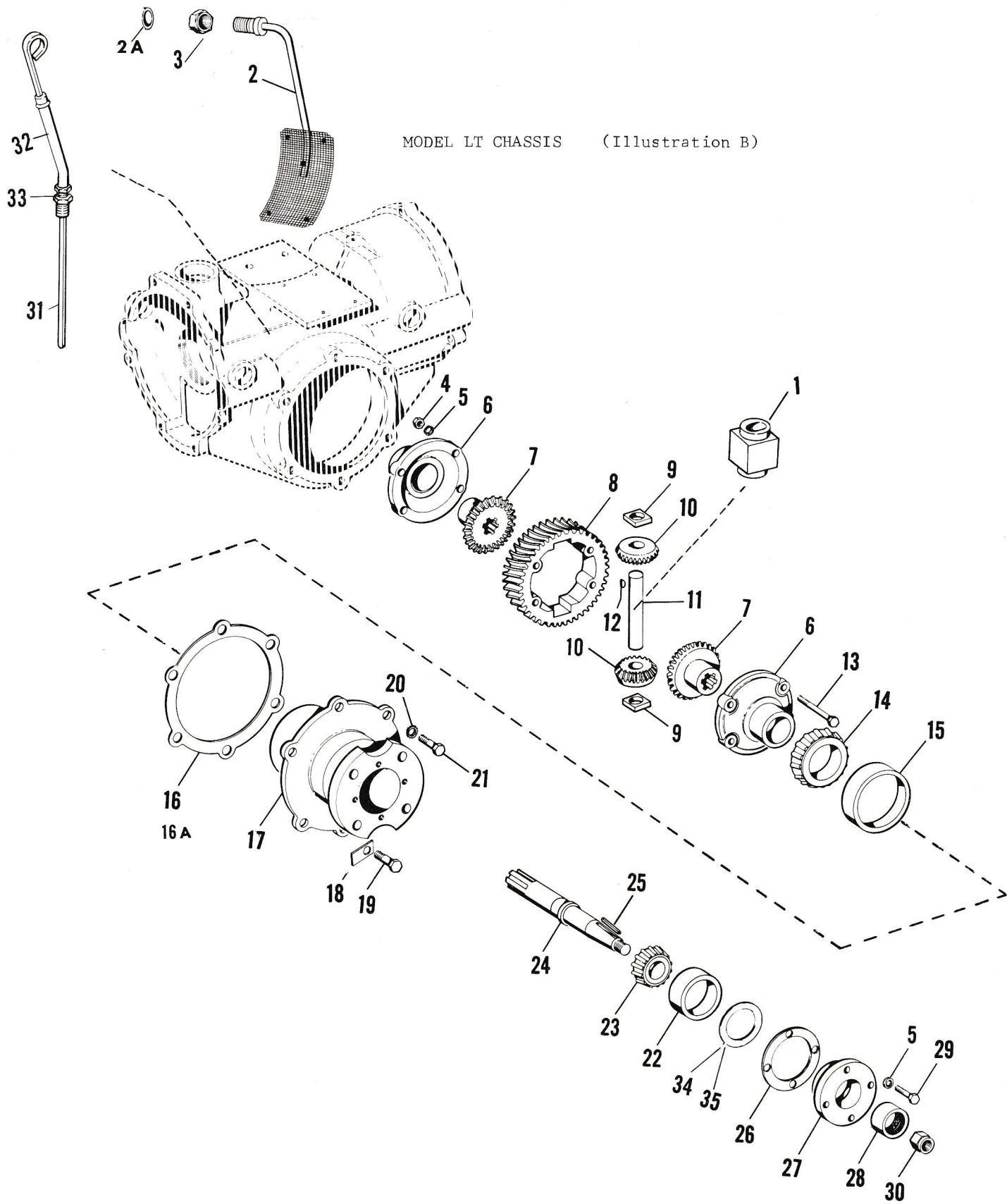

MODEL LT CHASSIS
ILLUSTRATION B

Item No.	Part No.	Description	Quan. Req'd.
1	L-606	Thrust Block	1
2	L-868	Oil Strainer Body	1
2-A	L-823-A	Gasket	1
3	218-N	Oil Strainer Nut	1
4	204-N	Nut	4
5	304-W	Bearing Cap Lock Washer	4
6	L-205	Differential Housing	2
7	L-604	Bevel Gear	2
8	L-602	Worm Gear, (Specify 4,6,or 8 Lead)	1
9	L-607-K	Driving Block, (with Keyway)	2
10	L-603	Bevel Pinion	2
11	L-605	Pinion Pin	1
12	501-K	Pinion Pin Key	1
13	L-206	Differential Housing Bolt	4
14	RB-111-C	Differential Bearing Cone	2
15	RB-111-R	Differential Bearing Race	2
16	L-220	Shim (.005 .020)	as req'd.
16-A	L-220-G	Gasket	2
17	L-203-E	Axle Housing	2
18	L-215	Oil Drain Washer Tab	1
19	123-S	Axle Housing Drain Bolt (nylon plug)	1
20	W-S-18	Lock Washer	11
21	122-S	Axle Housing Bolt	11
22	RB-110-R	Axle Bearing Race	1
23	RB-110-C	Axle Bearing (cone)	1
24	L-611	Axle	2
25	L-615	Axle Key	2
26	7103	Bearing Cap Gasket	2
27	L-204-E	Bearing Cap	2
28	L-208	Bearing Cap Oil Seal (double)	2
29	5 CH-6-C	Bearing Cap Bolt	8
30	227-N	Axle Nut	2
31	L-883	Dip Stick	1
32	L-884	Dip Stick Guide	1
33	L-885	Dip Stick Fitting	1
34	7106	.020 Shim	as req'd.
35	7107	.005 Shim	as req'd.

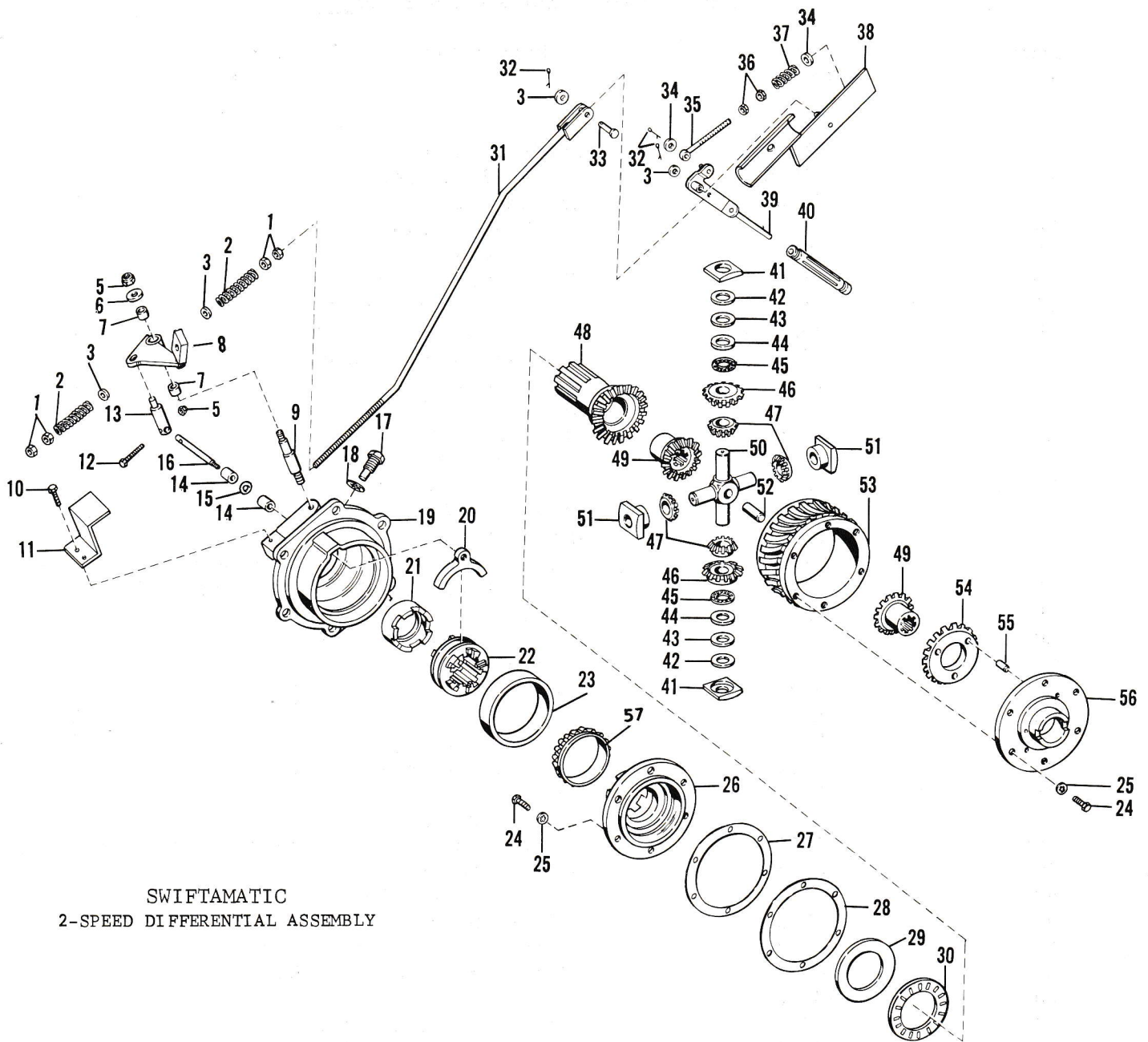

SWIFTAMATIC
2-SPEED DIFFERENTIAL ASSEMBLY

Item No.	Part No.	Description	Quan. Req'd.
1	205-N	Hex Nut	4
2	6750	Clutch Spring	2
3	403-W	Clutch Spring Washer, heavy	4
5	NTE-05C	Elastic Stop Nut	2
6	402-W	Flat Washer	1
7	6724	Pivot Bushing	2
8	6723	Shifter Arm	1
9	6725	Stationary Pivot Pin	1
10	191-S	Hex Head Cap Screw	2

2-SPEED DIFFERENTIAL ASSEMBLY Con't.

Item No.	Part No.	Description	Quan. Req'd.
11	6731	Shifter Guard	1
12	185-S	Hex Head Cap Screw	1
13	6726	Shifter Pin	1
14	6713	"O" Ring Retainer	2
15	6732	"O" Ring Seal	1
16	6721	Clutch Sliding Pin	1
17	6734	Stationary Clutch Bolt	1
18	309-W	Shake Proof Lock Washer	1
19	6728	Axle Housing 2-Speed	1
20	6719	Shifting Yoke	1
21	6720	Stationary Clutch	1
22	6718	Shifting Clutch	1
23	RB-123-R	Bearing Race	1
24	5CH-6C	Hex Head Cap Screw	12
25	304-W	Shake Proof Lock Washer	12
26	6717	Clutch Housing	1
27	6739	Clutch Housing & Worm Gear Shim .005 as req'd.	
28	6740	Clutch Housing & Worm Gear Shim .020 as req'd.	
29	6744	Thrust Race	1
30	6743	Needle Thrust Bearing	1
31	6758	Shifter Rod	1
32	602-C	Cotter Pin	3
33	L-722	Clevis Pin	1
34	401-W	Flat Washer	2
35	6757	Over Center Lock Spring Guide	1
36	201-N	Hex Nut	2
37	6755	Toggle Spring	1
38	6759	Shifting Handle Mounting Bracket	1
39	6756	Shifter Lever	1
40	5167	Handle Lever Grip	1
41	6715	Spider Thrust Washer	2
42	6738	Spider Thrust Shim .020	Opt.
43	6737	Spider Thrust Shim .005	2
44	6742	Thrust Race	2
45	6741	Needle Thrust Bearing	2
46	6702	Shifting Train Pinion	2
47	6708	Spider Gear	4
48	6704	Shifting Gear	1
49	6709	Differential Gear	2
50	6710	Spider Pin	1
51	6752	Differential Thrust Spacer	2
52	6711	Thrust Pin	1
53	6705	8 Start Worm Gear	1
54	6703	Pinned Gear	1
55	6714	Dowell Pin	3
56	6716	Pinned Housing	1
57	RB-123-C	Bearing Cone	1
	NN	Shifter Rod Assembly, Complete	1

OIL LINES, GASOLINE & MAGNETO ASSEMBLIES

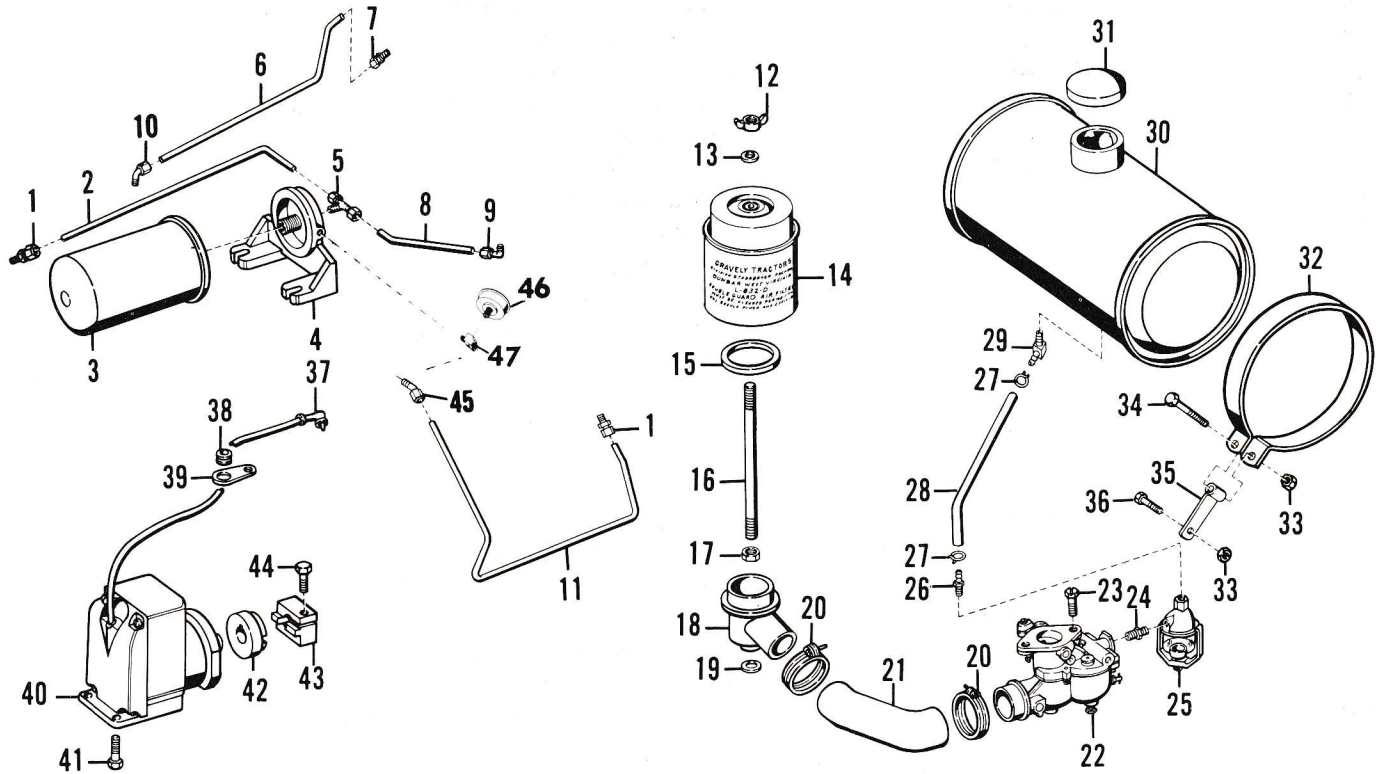

Item No.	Part No.	Description	Quan. Req'd.
1	8230	Relief Valve Connector	1
2	8259	Oil Line, Filter to Relief Valve	1
3	L-857	Oil Filter	1
4	L-858	Oil Filter Bracket	1
5	L-814-C	Discharge Line Tee	1
6	L-813-A	Intake Oil Line 5/16"	1
7	L-814-A	Pump Inlet Connector	1
8	L-860	Oil Line Filter to Engine	1
9	L-814-DL	Engine Elbow Long Style	1
10	L-814-F	Elbow, Oil Strainer	1
11	L-859	Oil Line Pump to Filter	1
12	EWN/4C	Wing Nut	1
13	401-W	Washer	1
14	L-832-D	Double Air Guard	1
15	L-832-H	Gasket	1
16	L-819-E	Air Filter Bolt	1
17	201-N	Hex Nut	1
18	L-833	Air Cleaner Bracket	1
19	L-837	Gasket	1
20	L-836	Hose Clamp	2
21	L-841	Air Filter Hose	1
22	8228	Carburetor	1
23	126-S	Carburetor Bolt	2
24	L-814-E	Gas Filter Nipple	1
25	L-705	Gas Strainer Complete	1

OIL LINES, GASOLINE & MAGNETO ASSEMBLIES Con't.

Item No.	Part No.	Description	Quan. Req'd.
26	L-842	Gas Line Connector	1
27	7216	Fuel Hose Clamp	2
28	L-844	Gas Line Hose	1
29	L-843	Elbow Carburetor to Gas Line	1
30	L-701	Gas Tank	1
31	2505-A	Gas Tank Cap	1
32	8257	Tank Band Right & Left	2
33	233-N	Elastic Stop Nut	4
34	149-S	Tank Band Bolt, Long	2
35	5164-B	Anchor Bracket	2
36	114-S	Tank Band to Fan Housing Bolt	2
37	1731	Spark Plug Wire	1
38	L-827	Rubber Grommet	1
39	L-826	Cable Bracket	1
40	L-808	Magneto	1
41	179-S	Magneto to Chassis Bolt	2
42	L-809-F	Float Member	1
43	L-811	Magneto Coupling	1
44	154-S	Magneto Coupling Bolt	1
45	L-814-D	Elbow 1/4"	1
46	L-866	Oil Pressure Gauge	1
47	L-867	Oil Pressure Gauge Adapter	1
NS	402-W	5/16" Flat Washer (used on Items 34 & 36)	4

SUPER HOOD ASSEMBLY

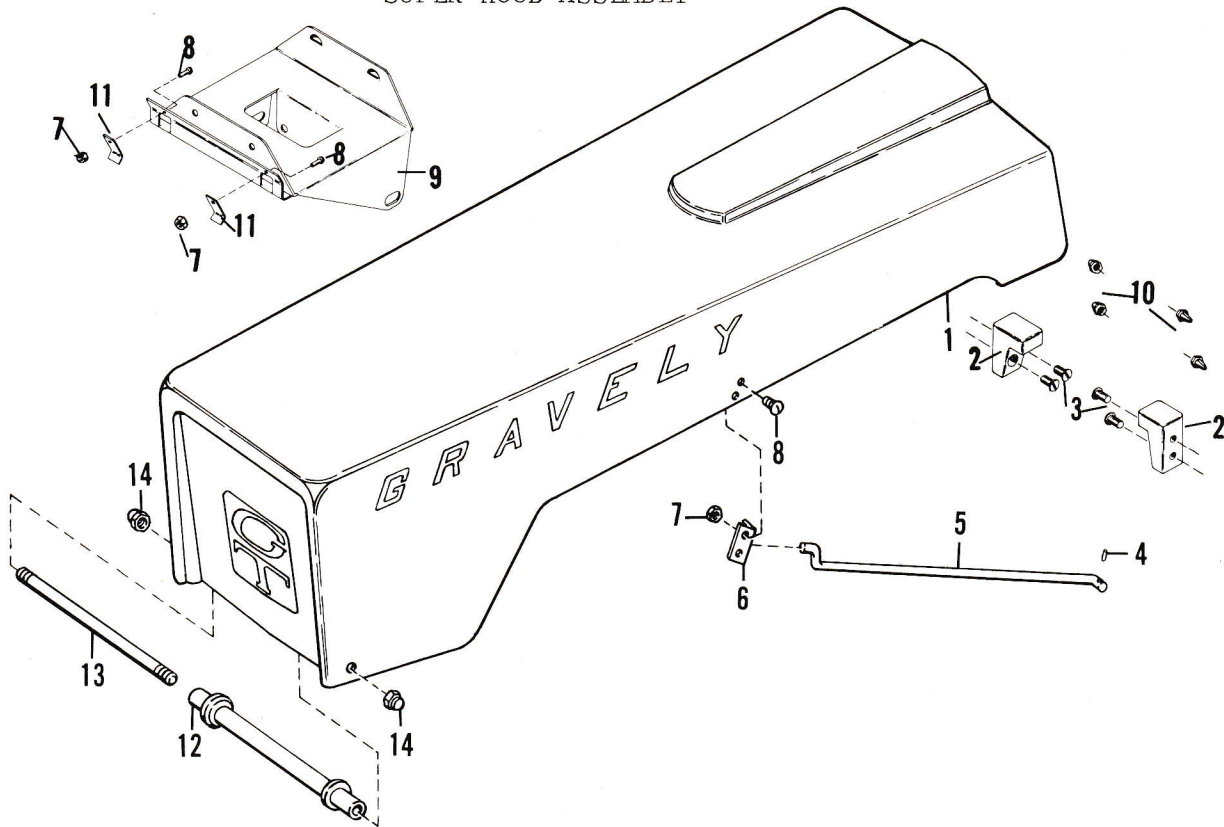

Item No.	Part No.	Description	Quan. Req'd.
1	ST-136	Super Hood	1

SUPER HOOD ASSEMBLY Con't.

Item No.	Part No.	Description	Quan. Req'd.
2	8280	Hood Bumper	2
3	436-732	Machine Screw	4
4	2 RP 4	Roll Pin	1
5	ST-129	Support Rod	1
6	ST-131	Hood Catch	1
7	207-N	Hex Nut	4
8	N-10-ST-5-C	Machine Screw	1
9	8261	Battery Bracket	1
10	441-256	Acorn Nut	4
11	8254	Spring	2
12	8251	Pivot Tube	1
13	8252	Pivot Rod	1
14	8253	Acorn Nut	2

HANDLES, CUSTOM HOOD AND CONTROL GROUPS

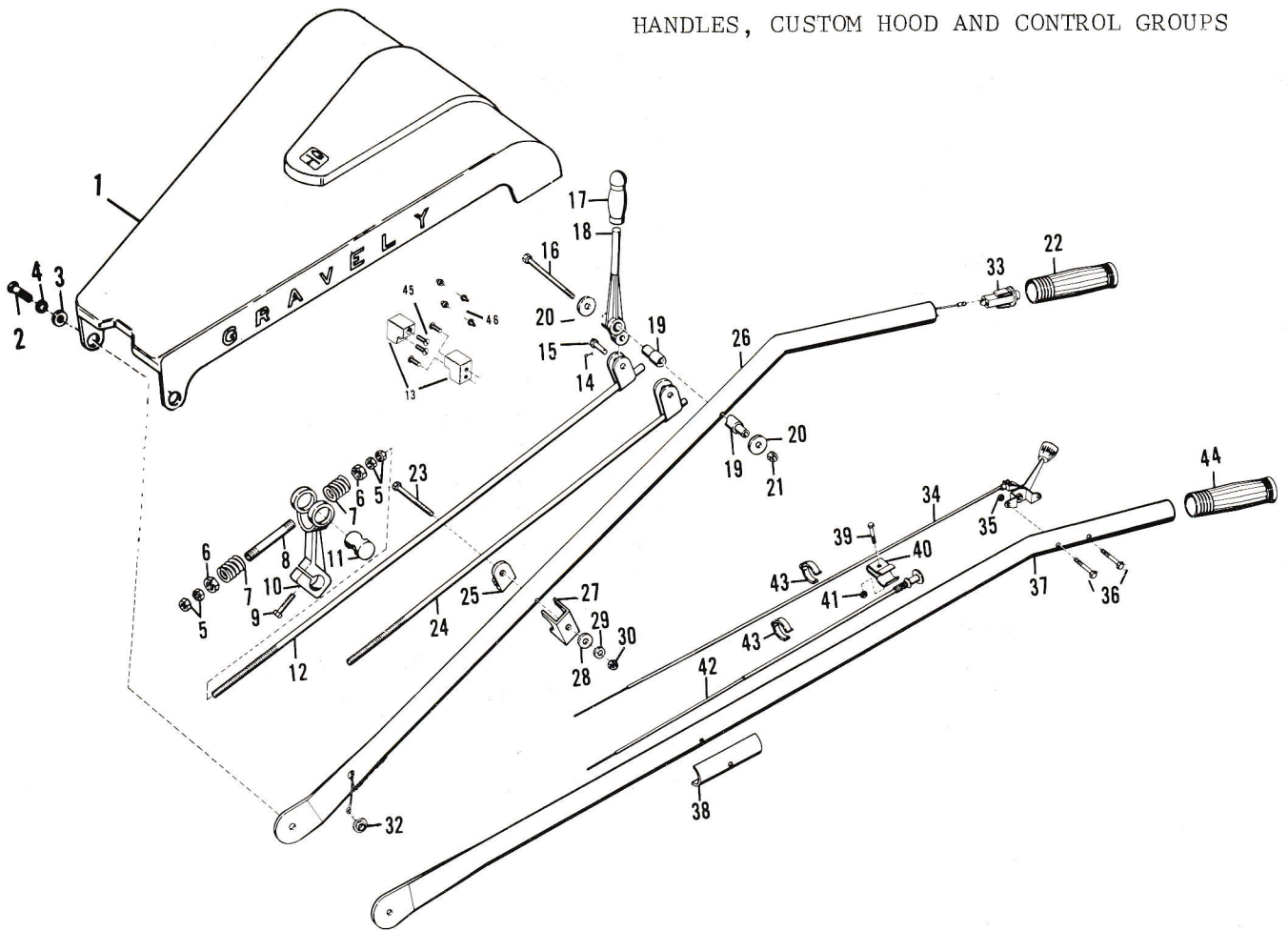

Item No.	Part No.	Description	Quan. Req'd.
1	L-820-B	Hood - Custom	1
2	112-S	Bolt	2
3	L-821	Hood Spacer	2
4	306-W	Lock Washer	2
5	206-N	Nut	8

HANDLES, CUSTOM HOOD AND CONTROL GROUPS Con't.

Item No.	Part No.	Description	Quan. Req'd.
6	210-N	Nut (Repairs Only)	4
7	L-729	Spring	4
8	L-730	Clutch Rod (Threaded-repairs)	2
9	154-S	Bolt	2
10	L-715	Clutch Actuating Lever	2
11	L-723	Clutch Rod Pivot	2
12	L-720-L	Clutch Rod - Long	1
13	8281	Hood Bumper	2
14	602-C	Cotter Pin	2
15	L-722	Clevis Pin	2
16	L-718	Bolt	1
17	5167	Hand Lever Grip	2
18	L-716	Clutch Hand Lever	2
19	L-717	Hand Lever Pivot	2
20	402-W	Flat Washer	2
21	233-N	Nut	1
22	L-725-R	Handle Grip-Right Side ($\frac{1}{2}$ "hole)	1
23	195-S	Bolt, Right (131-S Left)	2
24	L-720-S	Clutch Rod - Short	1
25	L-742	Clutch Rod Brace	1
26	L-724-R	Driving Handle - Right	1
27	L-728	Driving Handle Bracket	2
28	403-W	Flat Washer	2
29	306-W	Lock Washer	2
30	205-N	Nut	2
31	10-275	Wire	1
32	8265	Grommet	1
33	10-277	Stop Switch	1
34	8226	Throttle Control Lever Assy.	1
35	8267	Conelock Nut	2
36	8266	Pan Head Machine Screw	2
37	L-724-L	Driving Handle Left	1
38	L-726	Handle Clamp	2
39	8263	Bolt	1
40	G-107	Control Bracket	1
41	8264	Conelock Nut	1
42	8225	Choke Control Cable Assembly	1
43	8260	Choke and Conduit Clamp	2
44	L-725-L	Handle Grip Left Side	1
45	8276	Machine Screw	4
46	441-256	Acorn Nuts (Used W/8281)	4

FAN AND DEFLECTOR ASSEMBLY

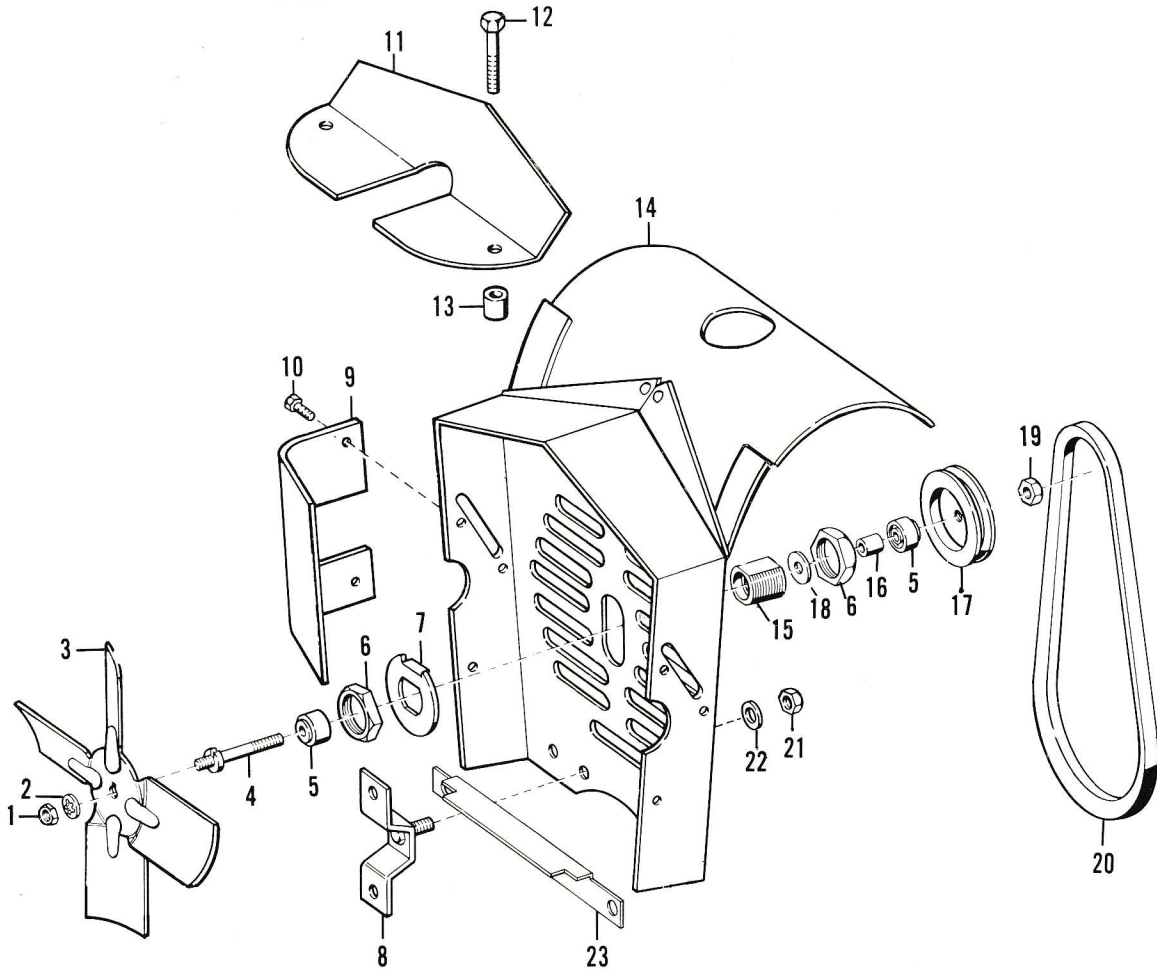

Item No	Part No.	Description	Quan. Req'd.
1	206-N	Fan Securing Nut	1
2	306-W	Fan Nut Lock Washer	1
3	L-805	Fan	1
4	5137	Fan Shaft	1
5	5139	Fan Ball Bearing	2
6	5134	Fan Bearing Lock Nut	2
7	L-830	Fan Bearing Lock Washer	1
8	L-224	Fan Housing Bracket	2
9	L-838-A-RH	Air Deflector, Right Hand	1
	L-838-B-LH	Air Deflector, Left Hand	1
10	156-S	Sheet Metal Screw	4
11	L-839	Cylinder Head Air Deflector	1
12	155-S	Long Cylinder Head Screw	2
13	L-840	Deflector Spacer	2
14	L-222	Fan Housing	1
15	5133	Fan Bearing Race Retainer	1
16	5165	Fan Bearing Spacer	1
17	L-802	Fan Pulley	1
18	401-W	Fan Pulley Jam Nut Washer	1
19	204-N	Fan Pulley Jam Nut	1
20	5163	Fan Belt	1
21	211-N	Hex Nut	2
22	308-W	Lock Washer	2
23	8202	Fan Housing Baffle	1

